

FLTX4L/5L/7L+-FLTZ5S/6S/7S+

Datasheet

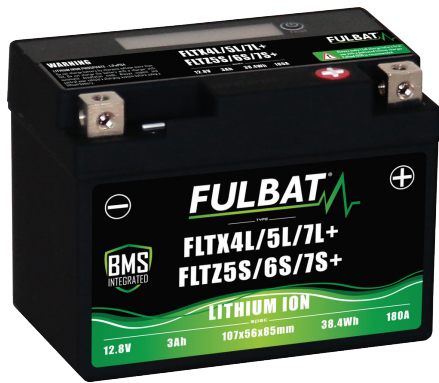

SPECIFICATIONS

Voltage	Capacity	CCA (EN)
12.8V	3.0Ah	180A
Energy	Charging current std.	Charging current max
38.4Wh	1.5A	3.0A

BMS FUNCTION:

- Over discharge protection
- Over charge protection
- Cell equalization

DIMENSIONS & WEIGHT

Length	107±2mm
Width	56±2mm
Total Height	85±2mm
Gross weight	0.60kg

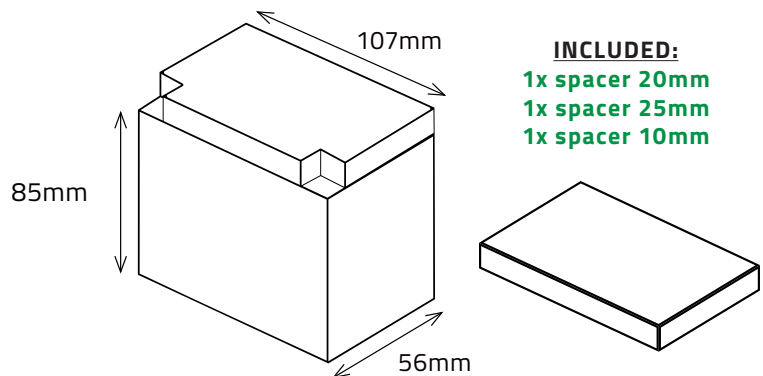

LiFePO4
NON-SPILLABLE



The new Lithium range is designed to offer the ultimate riding experience.

Ready to use and with ultra-light weight conception, this LiFePO4 range will ensure extreme starting performance, very low self-discharge and extreme cycle life. Thanks to the Battery Management System integrated, these batteries offer a very safe solution, ideal for the most demanding riders.

FEATURES

- Ready to use & Maintenance Free
- Ultra lightweight compare to lead acid battery
- Very high cold cranking performance
- Ultra safe thanks to the integrated BMS
- Very fast recharge
- Multi-positional fitment
- Integrated LCD battery tester
- Very low self-discharge

BATTERY REPLACEMENT

- | | |
|------------------|---------|
| ▪ FB4L-B | ▪ FTZ7S |
| ▪ FTX4L-BS/FTZ5S | ▪ FTZ7V |
| ▪ FTX5L-BS/FTZ6S | ▪ FTZ8V |
| ▪ FTX7L-BS | |

TERMINAL

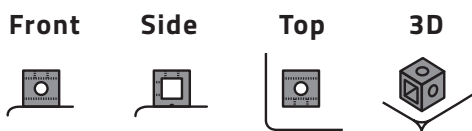

POLARITY



MOUNTING ANGLES

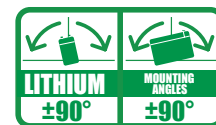

APPLICATIONS

