

FPC12-200

Datasheet

FULBAT[®]

INDUSTRIAL BATTERY



FPC Series are deep cycle batteries specially designed for long duration cyclic applications, ie with use in charge and then intensive discharge. With advanced AGM valve regulated technology and oversized negative plates, the FPC Series ensure very good cyclic performance with greater depth of discharge for mobility-type applications such as medical, golf and also renewable energies storage.

In harsh use conditions (high temperature, higher deep of discharge...), the Gel FPG range is recommended.

DIMENSIONS & WEIGHT

Length	522±2mm
Width	240±2mm
Total height	224±2mm
Gross weight	58kg

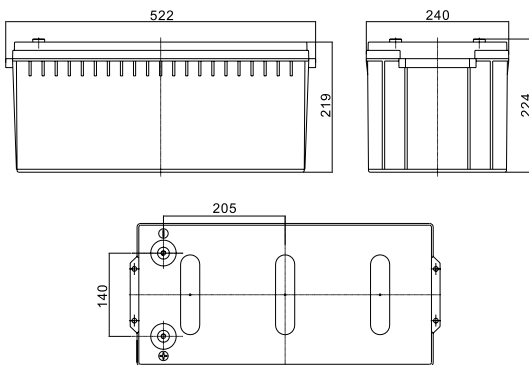

TERMINAL

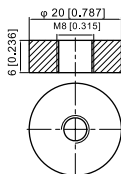

SPECIFICATIONS

Nominal voltage	12V (6 cells)
Nominal capacity	200Ah (10hr)
Cycle life	
(50% capacity @20°C)	Up to 350 cycles at 100% DOD
(50% capacity @20°C)	Up to 800 cycles at 50% DOD
Internal resistance	Approx 3.5mΩ
Terminal	T11
Max. discharge current	2000A (5 sec)
Reference capacity	200.0Ah (200hr, 1.80V/cell, 25°C) 190.5Ah (10hr, 1.80V/cell, 25°C) 170.0Ah (5hr, 1.75V/cell, 25°C) 150.0Ah (3hr, 1.75V/cell, 25°C)
Charge voltage	
Standby use voltage	13.6V ~ 13.8V 25°C Temperature compensation: -3mV/°C/Cell
Cycle use voltage	14.6V ~ 14.8V 25°C Temperature compensation: -4mV/°C/Cell
Operating temp. range	Discharge: -20°C ~ 60°C Charge: 0°C ~ 50°C Storage: -20°C ~ 60°C
Nominal operating temp. range	25°C ± 3°C
Self discharge	Can be stored for up to 6 months at 25°C and then recharging is recommended. Monthly self-discharge ratio is less than 3% at 25°C
Capacity affected by temp.	40°C 103% 25°C 100% 0°C 86%
Container material	A.B.S. UL94-HB UL94-V0 optional

APPROVALS

ISO9001 - Quality management system
ISO14001 - Environmental management System
Approved for transport by Air (IATA)
Designed in accordance with IEC 60896-21/22

APPLICATIONS



Renewable energy



Leisure & Marine

FPC12-200

Datasheet



CONSTANT CURRENT DISCHARGE (A) @25°C

F.V/Time	10min	15min	30min	1h	2h	3h	4h	5h	8h	10h	20h
1.60V/cell	437.1	350.7	215.6	121.5	72.34	56.35	44.20	37.60	24.12	20.00	10.37
1.65V/cell	402.6	327.9	204.3	117.3	69.92	54.62	42.88	36.42	23.93	19.81	10.31
1.70V/cell	373.1	308.4	193.7	113.6	68.05	52.31	41.56	35.43	23.55	19.43	10.18
1.75V/cell	342.3	288.9	186.0	110.0	65.44	50.96	40.42	34.45	23.17	19.24	10.00
1.80V/cell	311.5	264.5	179.2	105.1	63.20	50.00	39.48	34.00	22.79	19.05	9.903
1.85V/cell	243.8	218.9	151.9	93.83	57.80	46.54	37.02	31.30	21.46	17.90	9.811

CONSTANT POWER DISCHARGE (W/CELL) @25°C

F.V/Time	10min	15min	30min	1h	2h	3h	4h	5h	8h	10h	20h
1.60V/cell	744.2	611.7	391.8	228.0	136.8	107.0	85.19	71.17	47.00	39.22	20.69
1.65V/cell	716.6	594.8	382.6	224.1	133.1	104.3	83.11	69.24	46.62	38.85	20.51
1.70V/cell	668.8	563.0	364.2	217.6	129.8	100.3	80.47	67.51	46.06	38.09	20.32
1.75V/cell	622.4	531.4	351.5	211.5	125.1	97.86	78.58	65.97	45.30	37.71	19.95
1.80V/cell	573.4	491.2	340.1	202.9	122.3	97.31	77.07	65.09	44.55	37.34	19.77
1.85V/cell	454.9	412.7	291.7	182.2	112.6	90.77	72.53	60.20	42.11	35.26	19.58

DISCHARGE CHARACTERISTICS

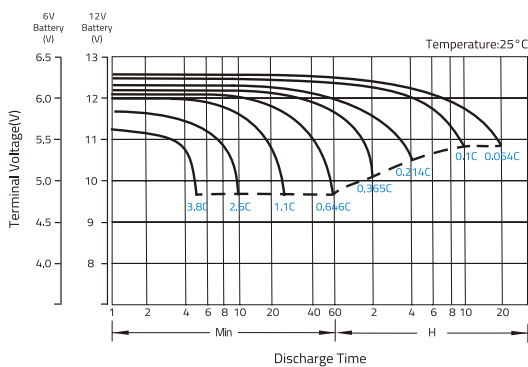

FLOAT CHARGING CHARACTERISTICS

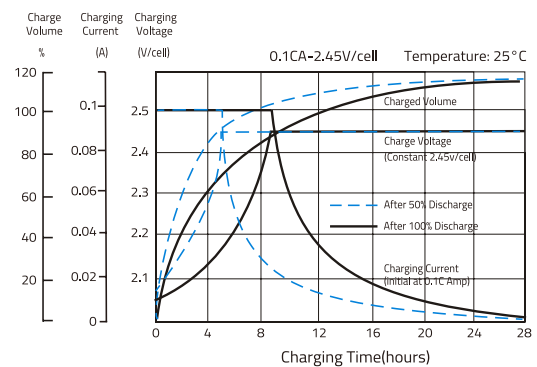

TEMPERATURE IN RELATION TO BATTERY CAPACITY

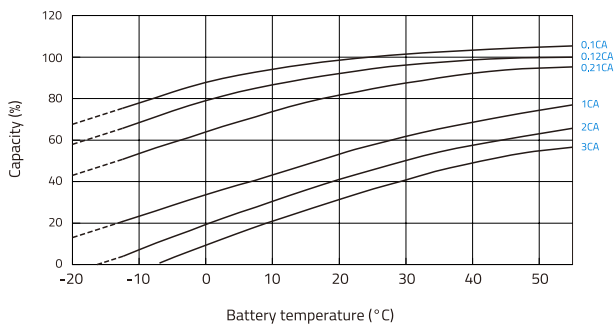

CYCLE LIFE IN RELATION TO DEPTH OF DISCHARGE

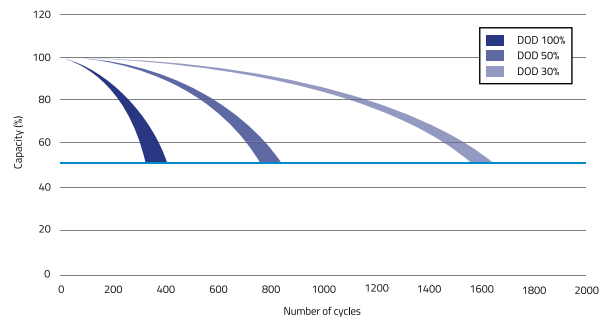

SELF DISCHARGE CHARACTERISTICS

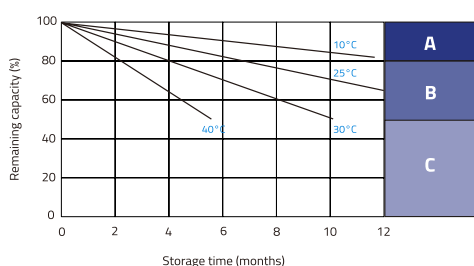

A No supplementary charge required
(Carry out supplementary charge before use if 100% capacity is required.)

Supplementary charge required before use. Optional charging way as below:

- B** Charged for above 3 days at limited current 0.25CA and constant voltage 2.25V/cell.
- Charged for above 20 hours at limited current 0.25CA and constant voltage 2.45V/cell.
- C** Charged for 8-10 hours at limited current 0.05CA.

C Supplementary charge may often fail to recover the capacity.
The battery should never be left standing till this is reached.